

**INSTRUCTION
MANUAL
FL-2100Z**

YAESU MUSEN CO., LTD.

TOKYO JAPAN

YAESU FL-2100Z LINEAR AMPLIFIER



The FL-2100Z is a compact, high-performance linear amplifier designed expressly for the FT-101ZD and FT-901DM HF SSB transceivers. This amplifier uses two 572B/T160 transmitting triodes in a Class AB₂ grounded grid configuration. Operation on the 160 through 10 meter bands is provided.

Two quiet internal fans provide forced air cooling for the final tubes. An internal change-over circuit biases the tubes to cutoff during receive operation, thereby eliminating unnecessary heat and diode noise generation. A unique safety feature incorporated in the design of the FL-2100Z is a momentary bias delay circuit, which protects the tank circuitry from damage by delaying the activation of the final tubes until the T/R relay is firmly seated.

An internal relay feeds the antenna through to the exciter during standby operation, or when the amplifier is turned off. A built-in SWR meter is also included, for monitoring of the feedline SWR during amplifier or exciter-only operation.

The power supply for the FL-2100Z is built in. It requires no warmup time, and its heavy-duty construction provides excellent regulation.

We recommend that you read this manual in its entirety before commencing operation. Operation of the FL-2100Z is extremely straightforward, but improper adjustment of the controls and switches could cause reduced power output or damage to the amplifier components. With proper care, the FL-2100Z will provide many years of reliable operation.

SPECIFICATIONS

Circuit type: Class AB ₂ grounded grid	Tube complement: 2 x 572B/T160
Frequency coverage: 160-10 meter amateur bands	Cooling system: Forced air
Plate input power: 1200 watts PEP SSB, 1000 watts CW, 400 watts AM/FM/FSK	Power requirements: AC 100/110/117/200/220/234 volts, 50/60 Hz
Plate voltage: 2400 VDC (no load)	Current consumption: AC 100-117 volts: 18 amps AC 200-234 volts: 9 amps
Drive requirements: 100 watts PEP for full output	Dimensions: 157(H) x 345(W) x 326(D) mm
Input impedance: 50 ohms, unbalanced	Weight: Approximately 20 kg
Output impedance: 50-75 ohms, unbalanced	Specifications subject to change without notice or obligation.
3rd order distortion products: -31 dB or better @ 1 KW PEP	

CAUTION

HIGH VOLTAGES ARE PRESENT WITHIN THE CABINET OF THIS APPARATUS. HARMFUL OR FATAL ELECTRIC SHOCK WILL RESULT IF HIGH VOLTAGE CIRCUITS ARE TOUCHED BY THE USER. REFER ALL SERVICE WORK TO AN EXPERIENCED TECHNICIAN.

DO NOT TURN ON THE FL-2100Z WITH THE TOP SHIELD COVER REMOVED. THE HIGH VOLTAGE SAFETY INTERLOCK WILL SHORT OUT THE HIGH VOLTAGE LINE, AND DAMAGE TO THE POWER SUPPLY CIRCUITRY WILL RESULT.

FRONT PANEL CONTROLS AND SWITCHES

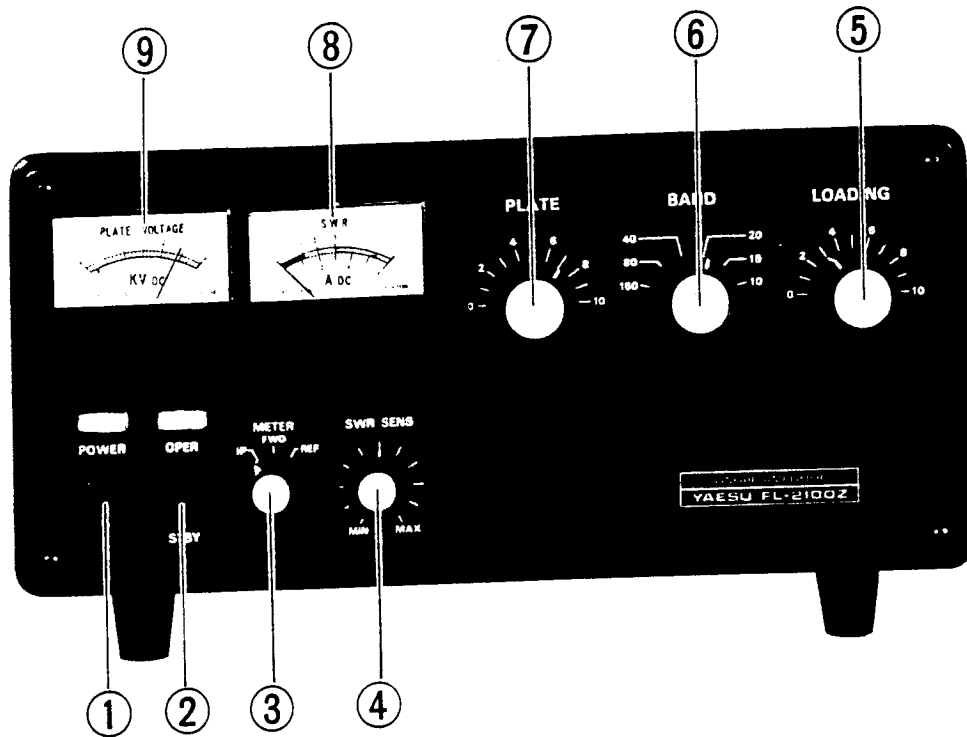

(1) POWER

This is the main power on/off switch for the amplifier.

(2) OPER/STBY

This switch applies bias to the final tubes during standby (STBY) operation, cutting them off. The relay is also disengaged in this condition.

(3) METER

The METER switch selects indication on the SWR/ammeter of plate current, relative forward power, and relative reflected power.

(4) SWR SENS

This control sets the SWR meter sensitivity level.

(5) LOADING

This control adjusts the tuning of the loading capacitor.

(6) BAND

This knob selects the band in use.

(7) PLATE

This control adjusts the tuning of the plate tank capacitor.

(8) SWR/AMMETER

This meter displays either the feedline SWR or amplifier plate current, depending on the position of the METER switch.

(9) PLATE VOLTAGE METER

The amplifier tubes' plate voltage is displayed on this meter.

REAR APRON CONNECTIONS

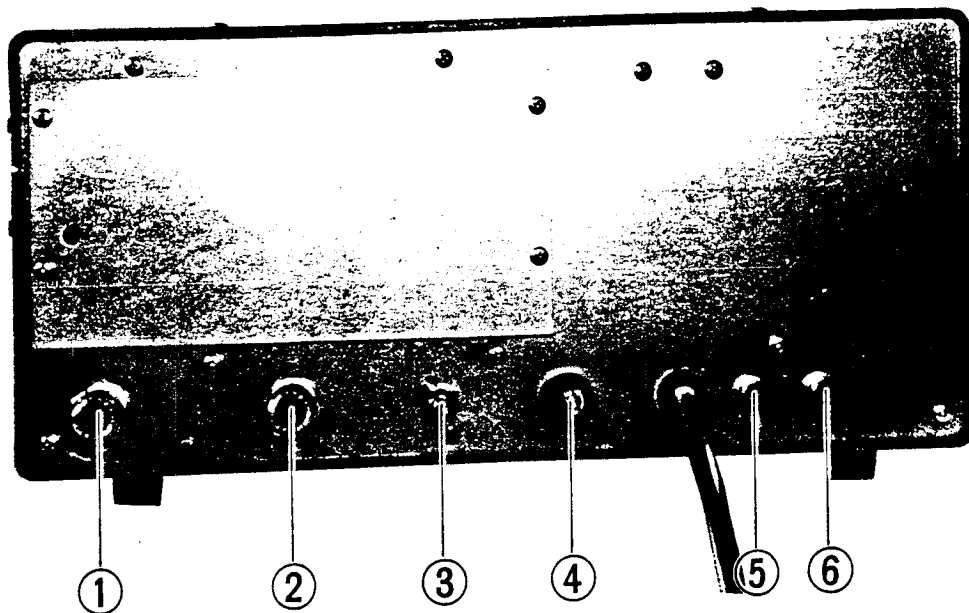

(1) RF OUT

This UHF connector provides the RF output to the antenna.

(2) RF IN

The RF input from the transceiver should be connected here.

(3) GND

Connect the amplifier to the station ground buss at this point.

(4) FUSE

For AC 100/110/117 volts, use a 20 amp fuse. For AC 200/220/234 volts, use a 15 amp fuse. Do not use a fuse of the improper rating.

(5) ALC

This RCA jack is used for connection to the transceiver ALC line.

(6) RY

This RCA jack is used for connection to the transceiver relay (normally open) contacts.

CAUTION

NEVER OPERATE THIS EQUIPMENT WITHOUT CONNECTING IT TO A GOOD EARTH GROUND. LIKEWISE, NEVER OPERATE THE AMPLIFIER WITHOUT HAVING AN ANTENNA OR DUMMY LOAD CONNECTED TO THE REAR PANEL RF OUT JACK.

INSTALLATION

UNPACKING AND INSPECTION

Carefully remove the FL-2100Z from its packing carton, and examine the unit for any signs of visible damage. Check the controls and switches for normal, positive action. If any damage has been sustained, document the damage completely, and notify the shipping company at once. Save the packing carton and foam packing material for possible use at a later date.

INSTALLATION PROCEDURE

In general, the amplifier should be situated in such a way as to allow free air circulation around the cabinet. Do not place books, papers, or other equipment on top of the FL-2100Z, and do not obstruct the free flow of air from the fan exhaust ports.

Refer to the interconnection diagram for details of a typical installation using the FL-2100Z and the FT-901DM or FT-101ZD. Pin 7 of the FT-901/101Z ACC jack is the ALC line, which should be connected to the FL-2100Z ALC jack. Pin 9 is the normally open contact of the relay used for amplifier switching; connect this pin to the FL-2100Z RY jack, and use a line to pin 8 as the common lead (for the shield of the RCA jack).

Use a short length of RG-58A/U or RG8A/U coax cable for the interconnection between the FT-901/101Z ANT jack and the FL-2100Z RF IN jack. For the output lead from the FL-2100Z RF OUT jack, do not use the small RG-58A/U type of cable, as its power rating is insufficient for the power level produced by the FL-2100Z.

When using an exciter other than the FT-901DM or FT-101ZD, the exciter should be capable of producing 100 watts PEP SSB output for full output from the FL-2100Z.

POWER CONNECTIONS

The FL-2100Z includes a built-in power supply capable of operation from AC 100/110/117/200/220/234 volts, 50/60 Hz. Before connecting the amplifier power cord to the AC supply mains, be absolutely certain that the voltage specification

marked on the rear apron of the amplifier matches your local supply voltage. Refer to the power transformer primary connection diagram when changing voltages.

It is essential that a fuse of the proper rating be used with this equipment. For AC 100/110/117 volts, use only a 20 amp fuse. For AC 200/220/234 volts, use only a 15 amp fuse.

WARNING

PERMANENT DAMAGE WILL RESULT IF IMPROPER AC SUPPLY VOLTAGE IS APPLIED TO THIS EQUIPMENT. OUR WARRANTY DOES NOT COVER DAMAGE CAUSED BY IMPROPER SUPPLY VOLTAGE OR USE OF AN IMPROPER FUSE.

If at all possible, the FL-2100Z should be operated from its own 220 volt AC line. The line should be fused for 10 amperes, and no other appliances should be run off the same circuit. If a 117 volt circuit is all that is available, it should be fused for 20 amperes, and circuit conductors should be no smaller than #10 AWG. UNDER NO CIRCUMSTANCES should the FL-2100Z be operated from a 117 volt house lighting circuit, as the circuit conductors are not large enough to carry this load.

ANTENNA REQUIREMENTS

The FL-2100Z has been designed for use with an antenna presenting a 50–75 ohm resistive load to the RF OUT jack. When using an antenna presenting an impedance which is far from this figure, we recommend the use of an antenna matching network in order to bring the antenna system impedance within the operating range of this amplifier.

GROUND

This amplifier should be connected to a good earth ground, using a heavy, braided cable not more than 10 feet long for connection to the station ground buss. The connection of the ground cable should be made to the rear apron GND terminal.

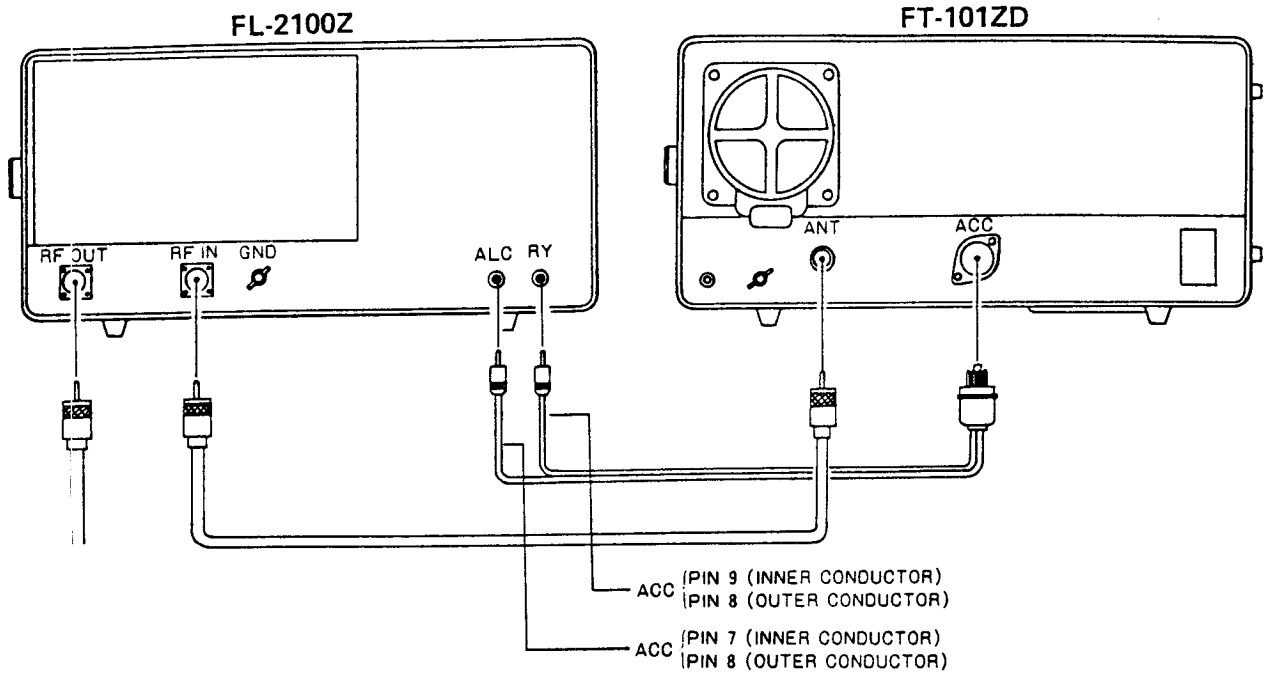

INTERCONNECTIONS

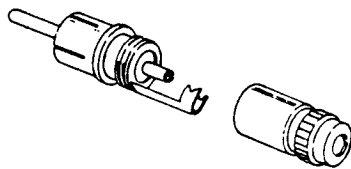

For test purposes, the RY plug may be jumpered as shown above.



For normal operation using the FT-101ZD relay, connect the RY plug as shown above.

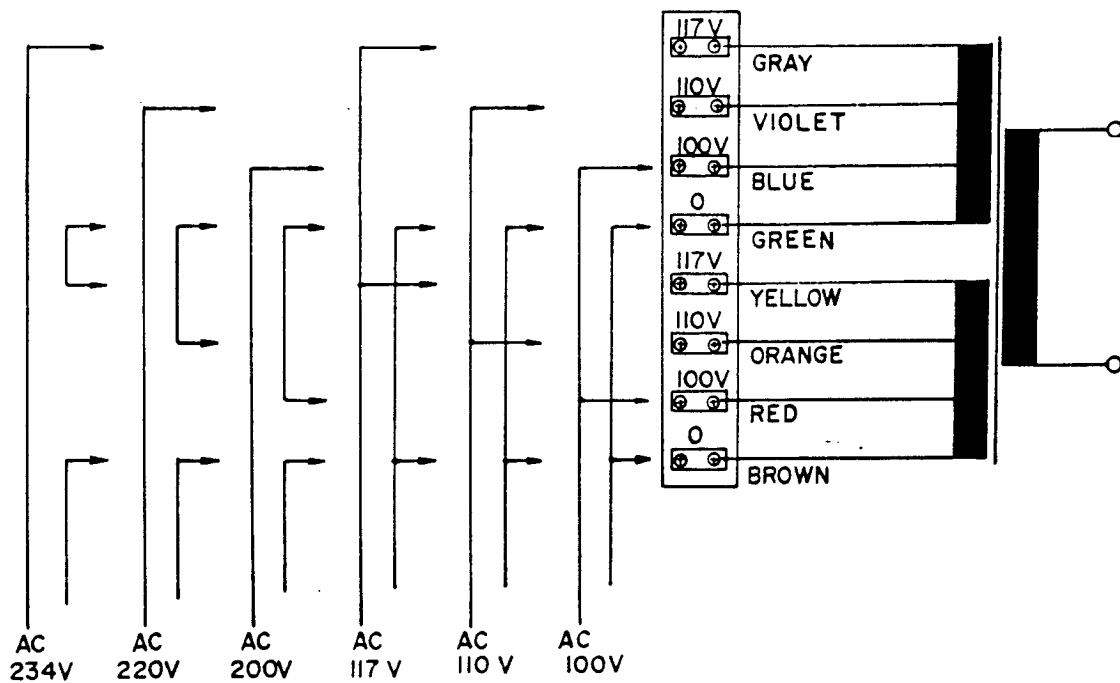

POWER TRANSFORMER PRIMARY CONNECTIONS

OPERATION

BEFORE COMMENCING OPERATION, CONFIRM THAT THE POWER TRANSFORMER PRIMARY HAS BEEN CORRECTLY WIRED FOR YOUR LOCAL AC SUPPLY VOLTAGE, AND CONFIRM THAT A FUSE OF THE PROPER RATING HAS BEEN INSTALLED. BE CERTAIN THAT AN ANTENNA IS CONNECTED TO THE RF OUT JACK.

The exciter may be tuned up with the amplifier on or off. If you tune up the exciter with the amplifier turned on, set the OPER/STBY to STBY during exciter tuning.

Preset the FL-2100Z controls and switches as follows:

POWER switch OFF

OPER/STBY switch STBY

METER switch IP

BAND switch Desired band

PLATE control To the position shown in Table 1.

LOAD control Fully counterclockwise to number 0.

Turn the FL-2100Z POWER switch ON, and recheck the exciter tuning with the OPER/STBY switch still set to STBY. Now rotate the exciter drive control fully counterclockwise (minimum drive level).

Set the OPER/STBY switch to OPER.

Close the exciter PTT switch, and slowly advance the drive control of the exciter until a reading of 0.2 amps is obtained on the FL-2100Z plate meter. Tune the FL-2100Z PLATE control for a dip (minimum meter reading) in the plate current indication on the meter. Return the exciter to standby (release the PTT switch).

Place the METER switch in the FWD position (to read relative forward power). Again apply drive from the exciter, and advance the SWR SENS control for a reading of approximately $\frac{1}{4}$ scale. Now advance the LOAD control in small increments, each time tuning the PLATE control for a maximum forward power reading. Adjust the SENS control, as necessary, to prevent off-scale deflection of the forward power meter.

DO NOT EXCEED 10 SECONDS OF KEY-DOWN TIME DURING TUNING, SO AS NOT TO DAMAGE THE EXCITER OF AMPLIFIER FINAL TUBES.

Peak power should occur at a plate current (IP) reading of approximately 0.5 amperes. Approximate settings of the FL-2100Z LOAD control for maximum output into a 50 ohm load are shown in Table 1.

When tuning, be certain to start at a very low drive level, and keep the plate current dipped. Likewise, do not begin tuning with the LOAD control advanced beyond the 0 point. The correct technique is to increase the exciter drive only after an initial dip is obtained in the plate current. With proper care taken in tuning, your FL-2100Z will provide many years of trouble-free operation.

The amplifier is now tuned for SSB and CW operation. For SSB operation, the exciter should be adjusted so that the FL-2100Z plate current indicates between 0.2 and 0.3 amperes under normal voice operating conditions. Because the meter cannot follow the current flow corresponding to the speech signal, the actual peak current value is approximately twice the value shown on the meter.

For AM operation, tune up the FL-2100Z as described above. Now adjust the exciter carrier level for a plate current indication of 0.2 amps with unmodulated carrier. If an exciter capable of FM or FSK operation is used with the FL-2100Z, do not exceed the ratings stipulated for AM operation.

For CW operation, set the drive level of the exciter for a power input of 1 kilowatt (e.g. 0.5 amps at 2000 volts plate current under load).

To measure the SWR at the antenna jack, set the meter switch to FWD (Forward), and apply RF power. Adjust the SWR SENS control for a full scale deflection of the SWR meter is observed. Now set the METER switch to REF (Reflected). The SWR may be read directly from the upper scale of the meter.

CIRCUIT DESCRIPTION

The FL-2100Z uses two 572B/T160 zero bias triodes in a Class AB₂ grounded grid configuration.

RF driving power from the exciter is applied to the tube filaments through the antenna changeover relay and an input pi network. The input circuits for each band are selected by input switch S₂B, which is ganged to the band switch, S₁.

The RF voltage appearing on the grids of the tubes is coupled through C₂₀₃ to ALC rectifier diodes D₂₀₁ and D₂₀₂ (1S1007). The plate potential at D₂₀₁ is determined by R₁, R₂, and R₃, so that adequate ALC voltage is available for control of the exciter.

The bias level is set by R₄. When the antenna relay is switched to the transmit condition, a timing circuit controls RL₃₀₁ to keep the tubes biased to cutoff until the antenna changeover relay is firmly seated. This protective feature prevents an unloaded condition caused by relay travel time from occurring. In standby, the cold end of S₄ is opened, biasing the tubes to cutoff.

The plate circuit is coupled to the 50 ohm output by an adjustable pi network. A 50 ohm SWR bridge circuit allows monitoring of forward and reflected relative power.

BAND	FREQ. (MHz)	PLATE	LOADING
160	1.8	1	1
	2.0	9	7
80	3.5	1	1
	4.0	6	3.5
40	7.0	4.5	1.5
	7.5	6	2.5
20	14.0	7	3
	14.5	7.5	3.5
15	21.0	8	4
	21.5	8.5	4
10	28.0	9	4
	29.7	10	4.5

Table 1

MAINTENANCE AND ALIGNMENT

WARNING

LETHAL VOLTAGES ARE PRESENT WITHIN THE CABINET OF THIS EQUIPMENT. BEFORE REMOVING THE CABINET OF THIS AMPLIFIER, UNPLUG THE POWER CORD FROM THE AC SUPPLY LINE. USE EXTREME CAUTION WHENEVER MAKING ANY ADJUSTMENTS INSIDE THE CABINET. NEVER WORK ON THIS AMPLIFIER WHILE ALONE: YOU MAY NEED SOMEONE TO TURN OFF THE POWER QUICKLY.

REMOVAL OF BOTTOM COVER AND CABINET

After disconnecting the AC power cable from the AC supply mains, the bottom cover of the amplifier may be removed by loosening the four screws on the bottom panel.

The chassis and panel assembly may be removed by the following procedure: remove the screws on the bottom of the cabinet, as well as the four screws near the front of the amplifier case. Once the screws are removed, the cabinet may be eased out towards the rear, away from the chassis and panel assembly.

REMOVAL OF THE PA COMPARTMENT SHIELD COVER

Once the cabinet is removed, the shield cover for the PA compartment may be removed by taking off the screws of the shield cover. A safety interlock will short out the filter capacitors when this is done, so AC power must not be applied with the shield cover removed.

Always discharge the plate cap to ground with an insulated screwdriver when working on the PA compartment circuitry. Wait at least ten minutes after turning the amplifier off before removing the shield cover.

TUBE REPLACEMENT

If replacement of the amplifier tubes becomes necessary, use tubes of identical manufacture as the originals. See your Yaesu dealer.

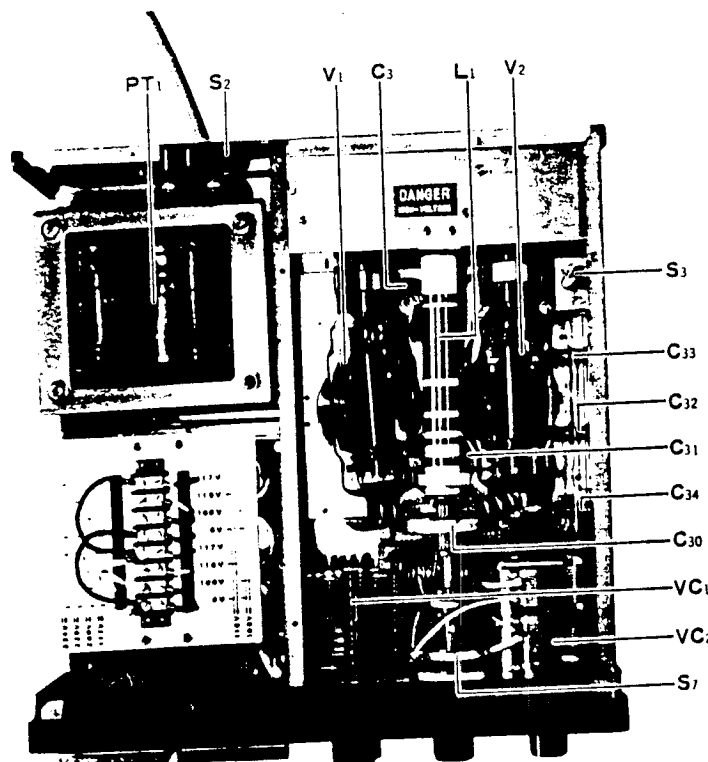

TOP VIEW

Fig. 1

TROUBLESHOOTING

Should trouble arise which cannot be cured by tube substitution, we recommend that the amplifier be returned to the dealer from whom you purchased it for servicing. If this is impossible, write to the Yaesu agent in your country, including as many details of the problem as possible. In countries where Yaesu is not currently represented, you may write directly to the factory: Yaesu Musen Co., Ltd., C.P.O. Box 1500, Tokyo, Japan. We will then advise you as to the best course of action.

Under no circumstances should troubleshooting or servicing of this equipment be attempted by anyone other than a technician experienced with high-power devices.

TUBE REPLACEMENT

Wait at least 10 minutes after having turned off the FL-2100Z. Disconnect the power cable from the AC supply outlet, and remove the cabinet of the amplifier. Remove the shield case of the PA compartment to gain access to the final tubes.

Before touching the final tubes be sure to discharge the plate caps of both tubes by shorting them to ground with an insulated screwdriver.

Once tube replacement is completed, replace the shield cover and the cabinet before plugging the AC cord into the AC supply outlet. Never apply AC power with the shield cover removed.

BIAS ADJUSTMENT

Set the OPER/STBY switch to OPER. Close the exciter PTT switch (SSB mode), and note the amplifier IP reading with no modulation (no RF input to the amplifier). The meter IP indication should be 0.09 amperes; if it is not, then adjustment of the bias setting is required.

Remove the bottom cover of the amplifier. Turn on the amplifier, and adjust R₄ for a reading of exactly 0.09 amps of idling current. Use extreme caution, as high voltage is present.

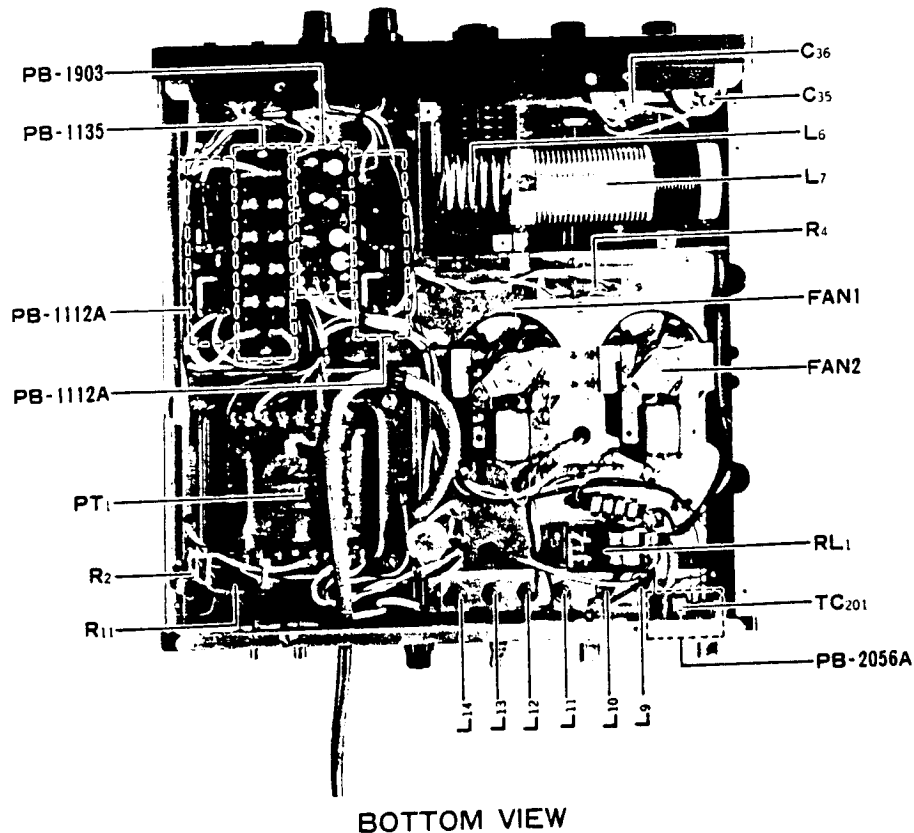

Fig. 2

SWR METER CALIBRATION

Connect a 50 ohm dummy load (100W rating) to the RF OUT jack. Tune up the exciter for 100 watts of RF output into the dummy load. Set the METER switch to FWD, and adjust the SWR SENS control for a full scale reading on the SWR meter. Now set the METER switch to REF, and adjust TC₂₀₁ for a reading of exactly 1 (no meter deflection) on the SWR meter.

INPUT COIL ADJUSTMENT

The input coils are adjusted at the factory for the center of each band, and are broad enough to cover the entire frequency range specified. However, if the final tubes are replaced with a brand other than that originally supplied, alignment of the input coils may be required.

Connect a dummy load (1 KW rating) to the RF OUT jack, and tune up the amplifier at the center of the band to be aligned at reduced power. Now adjust the coil appropriate for the band being aligned (L₉–L₁₄ for 160-10 meters, respectively) for maximum power output into the dummy load.

ALC LEVEL ADJUSTMENT

The ALC circuitry is designed to activate when the plate current reading exceeds 0.5 amperes.

Disconnect the ALC line to the transceiver. Tune up the exciter and amplifier in the usual fashion into a 50 ohm dummy load. Adjust the drive level of the exciter for a reading of 0.5 amps of plate current on the FL-2100Z IP meter.

Now reconnect the ALC line to the transceiver. Close the PTT switch, and adjust TC₁ for an identical 0.5 amp reading on the IP meter at the same setting of the exciter drive control. TC₁ may be accessed through the hole in the rear panel. See Figure 3.

AMPLIFIER NEUTRALIZATION

When new final tubes are installed, it may be necessary to neutralize the amplifier circuit again.

For this adjustment, remove the rear cover for the amplifier compartment. Use only an insulated screwdriver, and use extreme caution, because high DC and RF voltages are present in this compartment. Refer to Figure 3 for location data for TC₂, the neutralization capacitor. Keep one hand in your hip pocket while performing adjustments inside the amplifier compartment.

Tune up the amplifier for maximum power output at 29 MHz. At full drive, adjust TC₂ for a dip in the plate current, as shown on the front panel IP meter.

Do not exceed 10 seconds of key down time while performing this adjustment. The use of a foot-switch, or an assistant, is highly recommended.

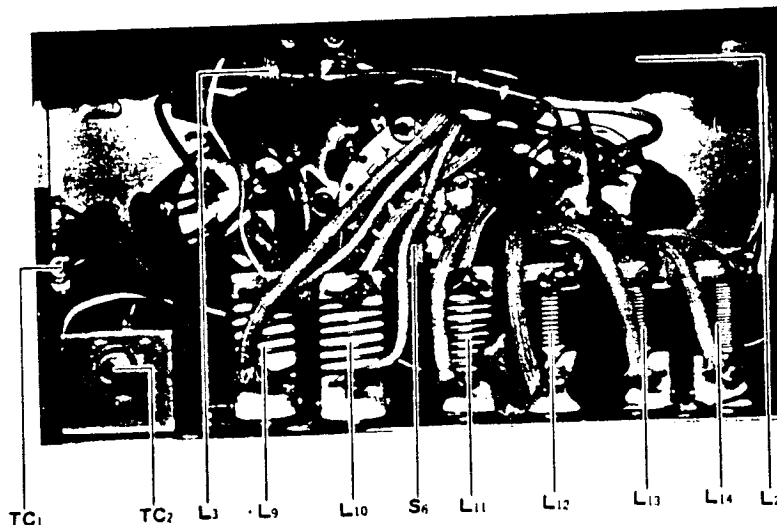

INPUT TUNING CIRCUIT COMPARTMENT

Fig. 3

MAIN CHASSIS			TRIMMER CAPACITOR			
Symbol No.	Parts No.	Description	TC1	K91000016	ECV-1ZW50x32	50pF
		VACUUM TUBE	TC2	K91000006	TSN-150C30P	30pF
V1,2	G6090005	572B/T160				
						INDUCTOR
		VACUUM TUBE SOCKET	L1	L1020660		
VS1,2	P3090047	DA204UX	L2	L1020659		
	S5000018	PLATE CAP HV-3001	L3	L1020661		
			L4,5(R6,9)	L1020656		
			L6	L0020758		
		DIODE	L7	L0020757		
D1	G2010070	Germanium 1S1007	L8	L1020064		
D2	G2090002	Silicon 10D10	L9	L0020764		
			L10	L0020763		
			L11	L0020762		
		RESISTOR	L12	L0020761		
R11	J01245512	Carbon film 1/4W TJ 5.1kΩ	L13	L0020760		
R5	J00305821	" RD1P821 820Ω	L14	L0020759		
R10	J10276472	" composition				
		1/2W GK 4.7kΩ				
R6,9(L4,L6)	-	" " 3W 22Ω				POWER TRANSFORMER
R7,8	J10336330	" " 3W 33Ω	PT1	L3030012		
R1	J20336473	Metallic film 2W 47kΩ				
R4	J31406300	Wire wound variable 10W				
		RWH-10G1 30Ω				METER
R3(with M1)	-	Meter shunt 0.14Ω	M1(with R3)	M0090013		
R2		RH2HVD 3MΩJ	M2	M0090012		
		POTENTIOMETER				RELAY
VR1	J60800068	EVH-B0AS20B54 50kΩB	RL1	M1090001	AW5221-HP2	DC12V
		CAPACITOR				SWITCH
C11	K30279003	Dipped mica 500WV 2pF	S1,4	N7090005	WD9223	
C38	K30279070	" " " 39pF	S2	N7090023	AM2317	
C18	K30279112	" " " 51pF	S5	N0190060	ESR-E143R-20Z	
C20	K30279071	" " " 56pF	S3	R0011670A	Safety Switch Ass'y	
C19	K30279029	" " " 120pF	S6	N0050033	Band Switch C Ass'y	
C22	K30279031	" " " 150pF	S7	N0050034	" " D Ass'y	
C21	K30279033	" " " 180pF				
C24	K30279085	" " " 330pF				
C23	K30279086	" " " 360pF				FAN MOTOR
C25	K30279089	" " " 510pF	FAN1,2	M2190001	2S10A (with fan)	
C26	K30279113	" " " 680pF				
C27	K30279049	" " " 820pF				
C29	K30279055	" " " 1500pF				LAMP
C16,17	K30279059	" " " 2200pF	PL1,2	Q1000033	K0252-6-8 14V 40mA	
C28	K30279060	" " " 2400pF				
C1,2	K12329001	Ceramic ECK-DAL103PE 0.01μF				
C4~7,12~15	K12279002	" ECK-D2H103PE 0.01μF				FUSE
C8,9	K00359002	" CC45SL3F221KY 220pF	F1	Q0000009	100V-117V 20A	
C37	K13170473	" 50WV 0.047μF		Q0000008	200V-234V 15A	
C36	K24356101	" RDA30-100P 100pF				
C35	K24356251	" RDA30-250P 250pF				
C31~34	K24356501	" RDA40-500P 500pF				FUSE HOLDER
C3	K24356102	" RDA30-1000P 1000pF	FH1	P2000001	SN1001	
C30	K24356502	" RDA40-5000P 5000pF				
						RECEPTACLE
		VARIABLE CAPACITOR	J1,2	P1090028	MBR-06B	
VC1	K90000032	YP-120-22 120pF	J3,4	P1090133	STR-01-3	
VC2	K90000031	530Px3L 530pFx3				

AC CORD			CM COUPLER		
	T7600001	2 wire, 2 prong plug	L201	L0020301A	
	T9000382	3 wire, 3 prong UL plug			
	T9000680	3 wire, 3 prong Australian plug			
	T9000584	3 wire, 2 prong EU plug			
BIAS CONT. BOARD					
			Symbol No.	Parts No.	Description
			PB-1903	F0001903	Printed circuit board
				C0019030	PCB with components
TERMINAL BLOCK					
	Q6000041	ML-3391-8P (H)			
RECTIFIER BOARD					
			D301,302,304, 305	G2090001	Silicon 10D1
Symbol No.	Parts No.	Description	D303	G2090002	" 10D10
PB-1135	F0001135	Printed circuit board			
	C0011350	PCB with components			
DIODE					
D101~110	G2090002	Silicon 10D10	R304	J10276151	Carbon composition 1/2W GK 150Ω
			R303	J10276473	" " " " 47kΩ
			R306	J10276224	" " " " 220kΩ
RESISTOR					
R101~110	J10276474	Carbon composition 1/2 GK 470kΩ	R305	J20306330	Metallic film 1W 33Ω
			R301,302	J20336560	" " 2W 56Ω
CAPACITOR BOARD (A) (B)					
			C305	K40100337	Electrolytic 10WV 330μF
Symbol No.	Parts No.	Description	C306	K40149003	" 25WV 100μF
PB-1112A	F0001112A	Printed circuit board	C301,304	K40149002	" " " 470μF
	C0011120	PCB with components	C302,303	K40180476	" 63WV 47μF
RESISTOR					
R111~113(A) R114~116(B)	J20336224	Metallic film 2W 220kΩ	RL301	M1190002	RELAY FBR211AD012M
ACCESSORIES					
			Symbol No.	Parts No.	Description
C101~103(A) C104~106(B)	K43270004	Electrolytic 500WV 100μF (ECE-M500V100E)		P0090019	Coaxial plug MP-7
				P0090018	Phono plug STP-58
				Q0000009	Fuse 20A (100~117V)
				Q0000008	" 15A (200~234V)
COUPLER UNIT					
Symbol No.	Parts No.	Description			
PB-2056A	F0002056A	Printed circuit board			
	C0020560	PCB with components			
DIODE					
D201,202	G2090038	Schottky barrier 1SS16			
RESISTOR					
R202	J01245470	Carbon film 1/4W TJ 47Ω			
R201	J00245102	" " " VJ 1kΩ			
R203,204	J00245472	" " " " 4.7kΩ			
CAPACITOR					
C201	K30176471	Dipped mica 50WV 470pF			
C202,203	K13170473	Ceramic " 0.047μF			
TRIMMER CAPACITOR					
TC201	K91000019	ECV-1ZW 10x40 10pF			

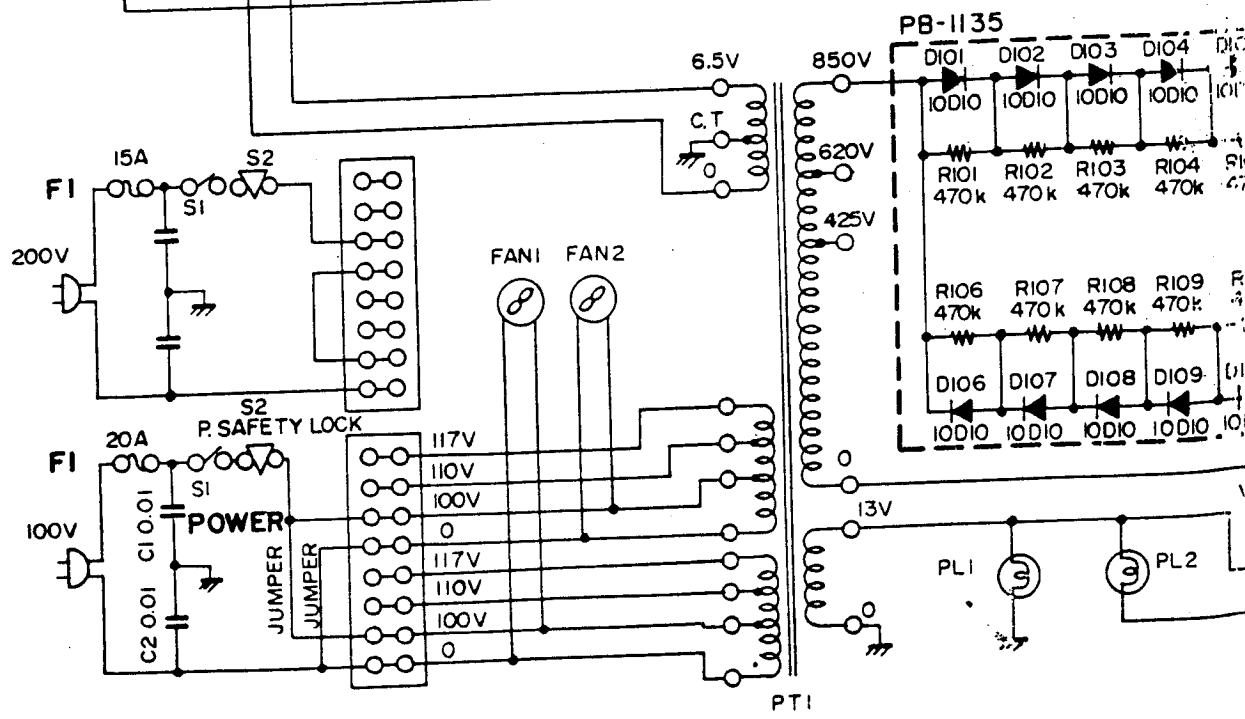
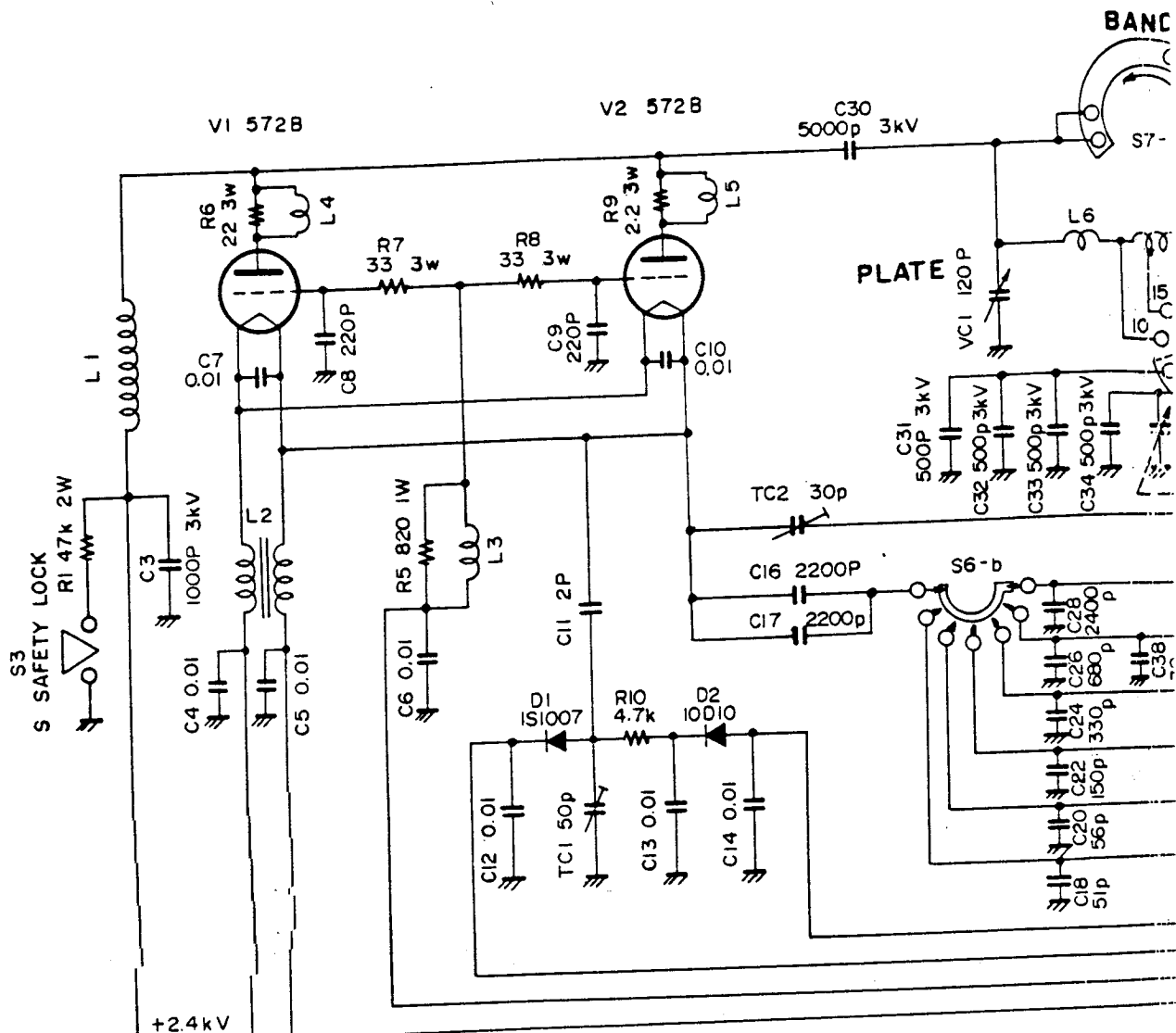

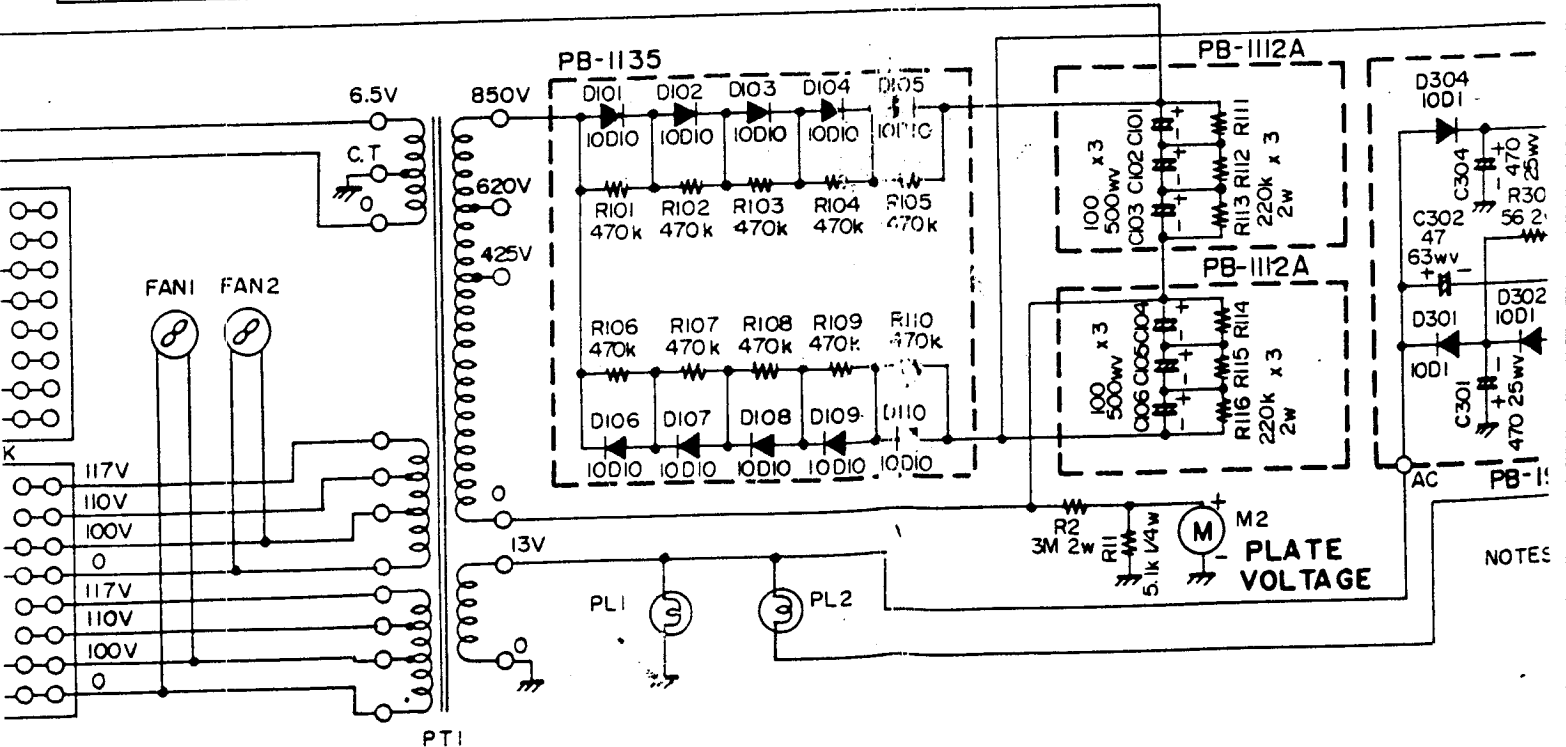
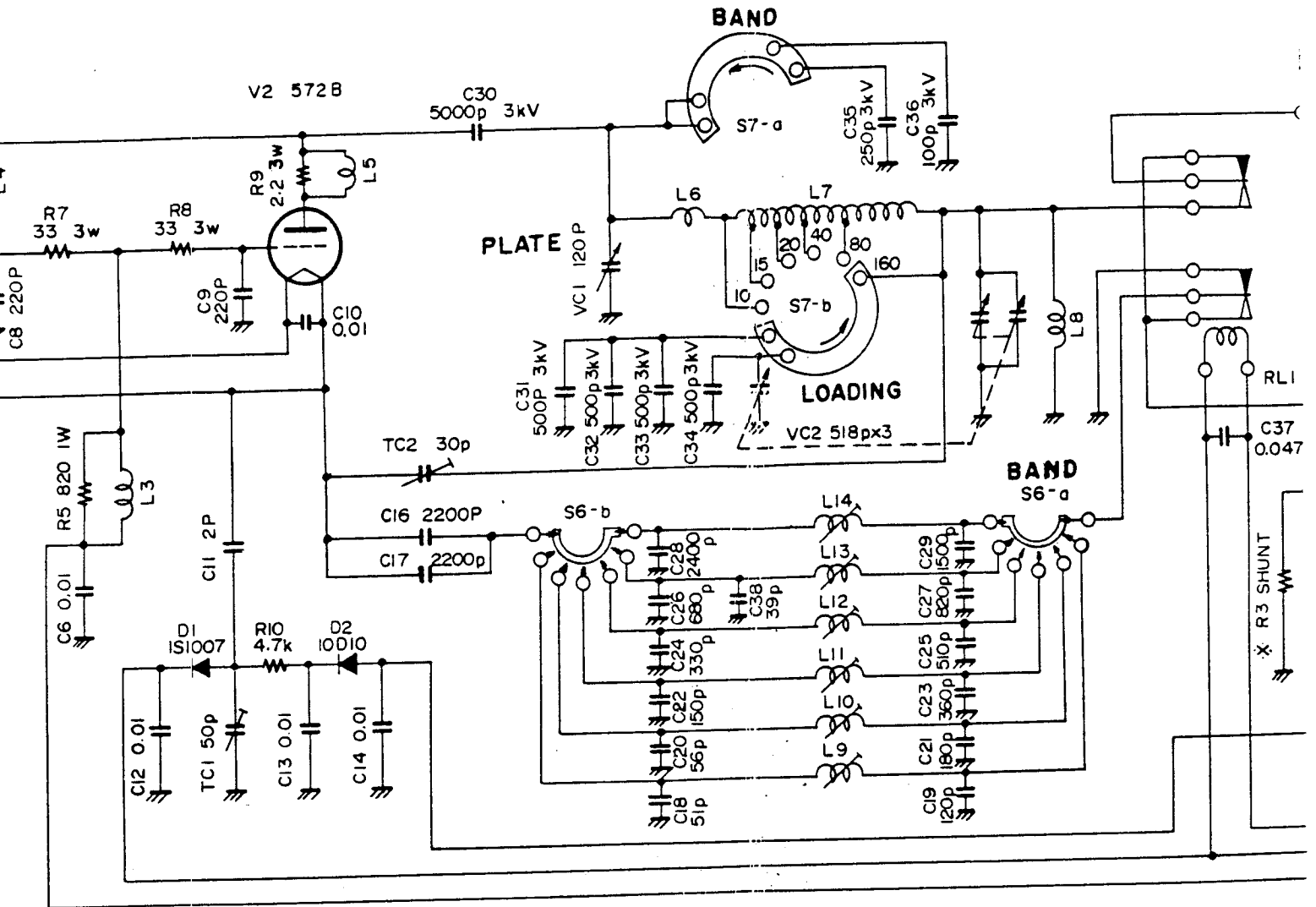

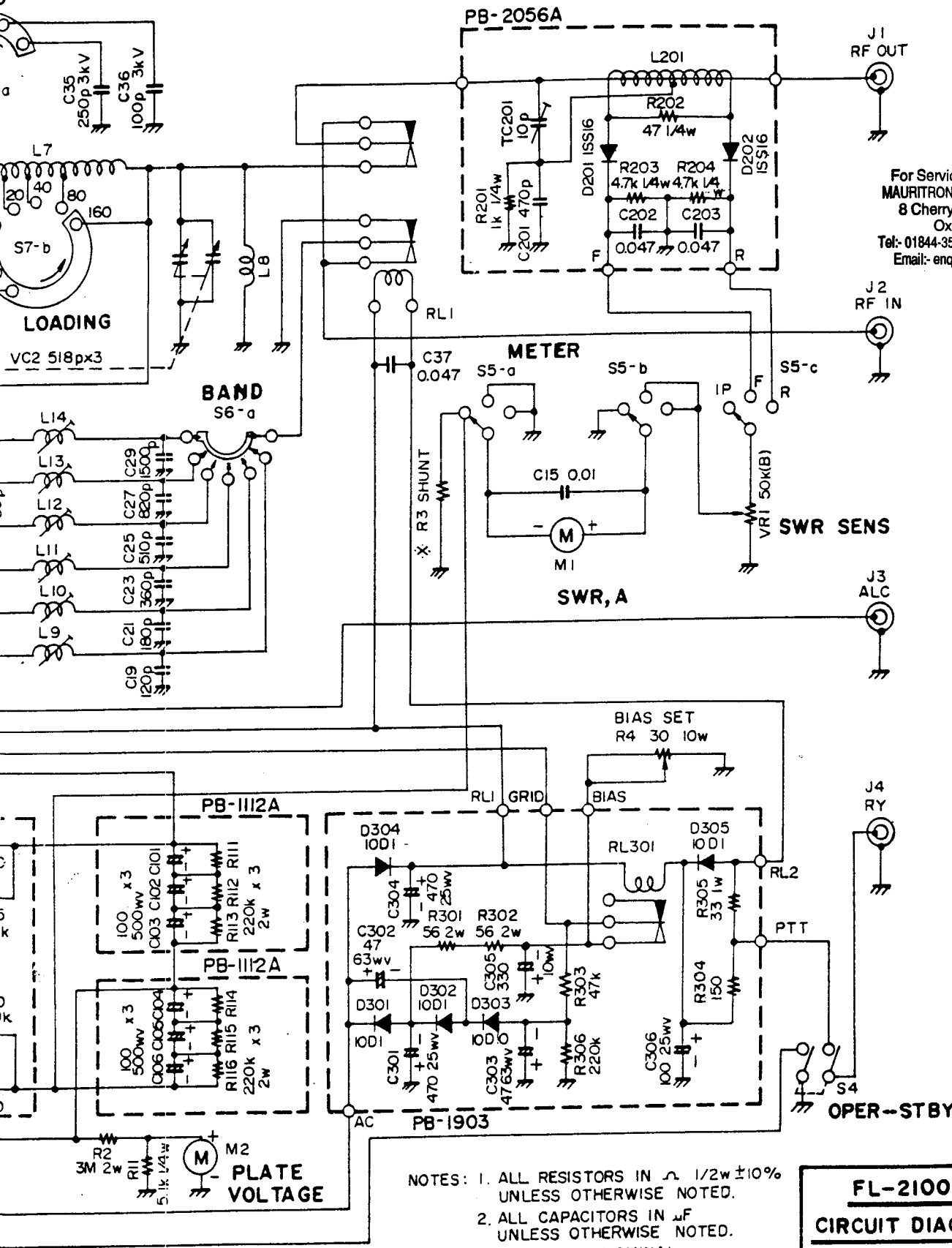

For Service Manuals Contact
MAURITRON TECHNICAL SERVICES
 8 Cherry Tree Rd, Chinnor
 Oxon OX9 4QY
 Tel: 01844-351694 Fax: 01844-352554
 Email: enquiries@mauritron.co.uk

- NOTES: 1. ALL RESISTORS IN Ω 1/2W $\pm 10\%$ UNLESS OTHERWISE NOTED.
 2. ALL CAPACITORS IN μF UNLESS OTHERWISE NOTED.
 3. * VALUE IS NOMINAL.

FL-2100Z
CIRCUIT DIAGRAM